

ELR H5-I-SC- 24DC/500AC-9

Order No.: 2900576



<http://eshop.phoenixcontact.de/phoenix/treeViewClick.do?UID=2900576>

"3 in 1" hybrid motor starter for reversing 3~ AC motors up to 550 V AC, with 24 V DC input, 9 A output current, and adjustable overload shutdown.



Commercial data	
GTIN (EAN)	
Note	Made-to-order
sales group	G421
Pack	1 pcs.
Customs tariff	85364900

Product notes

WEEE/RoHS-compliant since:
02/09/2010



<http://www.download.phoenixcontact.com>
Please note that the data given here has been taken from the online catalog. For comprehensive information and data, please refer to the user documentation. The General Terms and Conditions of Use apply to Internet downloads.

Technical data

Input data	
Rated control supply voltage U_s	24 V DC
Rated control supply voltage range with reference to U_s	0.8 ... 1.25
Rated control supply current I_s	35 mA

Rated actuating voltage U_c	24 V DC
Rated actuating voltage range with reference to U_c	0.8 ... 1.25
Rated actuating current I_c	3 mA
Switching threshold "0" signal, voltage	9.6 V
Switching threshold "1" signal voltage	19.2 V
Protective circuit	Protection against polarity reversal Parallel polarity protection diode
	Surge protection
Typical response time	< 35 ms
Typical turn-off time	< 40 ms
Operating voltage display	Green LED
Status display	Yellow LED
Indication	Red LED

Output data, load relay

Output name	AC output
Nominal output voltage	500 V AC
Nominal output voltage range	48 V AC ... 550 V AC
Load current	max. 9 A (see derating curve)
Leakage current	0 mA
Residual voltage	< 0.5 V
Surge current	100 A ($t = 10$ ms)
Type of protection	Surge protection
Output name	Acknowledge output
Note	Confirmation 01: Floating PDT contact
Nominal output voltage	max. 253 V AC 0% ... 100% (300 V DC)
Continuous load current	2 A

Output data, signaling contact

Measuring via	Current transformer for line current on L1 and L3
---------------	---

Connection data

Connection method	Screw connection
Conductor cross section solid min.	0.14 mm ²
Conductor cross section solid max.	2.5 mm ²
Conductor cross section stranded min.	0.14 mm ²
Conductor cross section stranded max.	2.5 mm ²

Conductor cross section AWG/kcmil min.	26
Conductor cross section AWG/kcmil max	12
General data	
Width	22.5 mm
Height	99 mm
Depth	114.5 mm
Test voltage input/output	4 kV _{rms}
Ambient temperature (operation)	-25 °C ... 70 °C
Ambient temperature (storage/transport)	-25 °C ... 70 °C
Mounting position	Vertical (horizontal DIN rail)
Assembly instructions	Can be aligned with spacing = 20 mm
Operating mode	100% operating factor
Degree of protection	IP20
Name	Standards/regulations
Standards/regulations	DIN EN 50178
	EN 60947
Name	Power station requirements
Standards/regulations	DWR 1300 / ZXX01/DD/7080.8d
Name	Air and creepage distances between the power circuits
Standards/regulations	DIN EN 50178
Rated surge voltage / insulation	6 kV/safe isolation
Rated insulation voltage	500 V
Pollution degree	2
Surge voltage category	III

Certificates / Approvals



Certification CB, CUL Listed, UL Listed

Certification Ex: PTB

Diagrams/Drawings

Block diagram

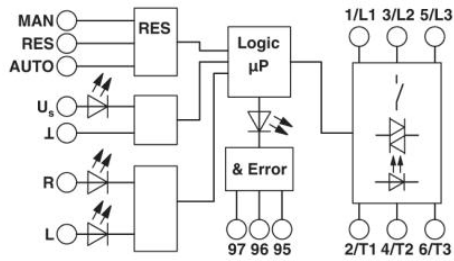

Circuit diagram

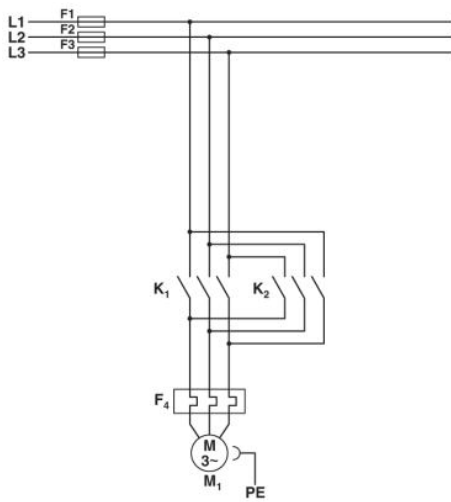

Conventional structure

Main current path for contactor according to category 3
 K1 = Left contactor
 K2 = Right contactor
 F4 = Motor protection relay

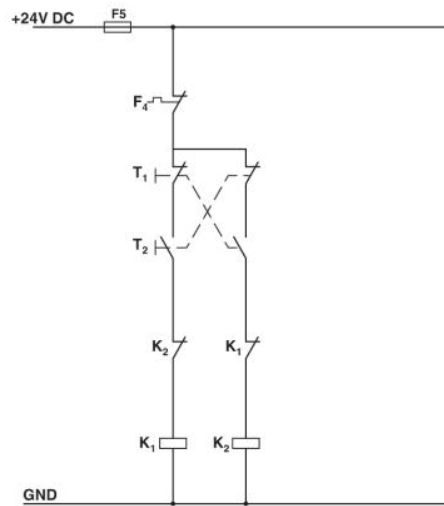

Conventional structure

Control current path for contactor according to category 3
 K1 = Left contactor
 K2 = Right contactor
 T1 = Left, T2 = Right, T3 = Reset
 F4 = Motor protection relay

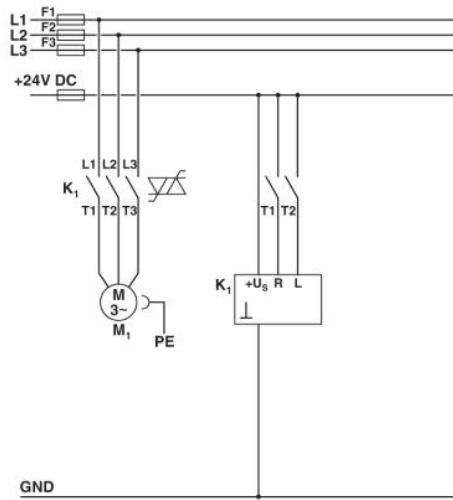

Structure with CONTACTRON

Main and control current path for "3 in 1" hybrid motor starter according to category 3

K1 = "3 in 1" hybrid motor starter

T1 = Right, T2 = Left, T3 = Reset

Address

PHOENIX CONTACT Inc., USA
586 Fulling Mill Road
Middletown, PA 17057, USA
Phone (800) 888-7388
Fax (717) 944-1625
<http://www.phoenixcon.com>



© 2011 Phoenix Contact
Technical modifications reserved;